

**Play value**

The Swing Rope Equipment consists of a steel cable spanned horizontally between two high posts. Attached to the cable are three ropes for swinging. Because of the way the apparatus is made, swinging movements on one rope affect swinging movements on an adjacent rope, thus paving the way for games of a competitive and cooperative nature and promotes communication and cooperation.

**Fundamental characteristics**

- The long swing ropes are connected by a horizontal steel cable and thus affect each other.
- Incentive for playing: unusual suspension
- Movement: swinging, swaying, hanging, jumping off

**Recommended for**

- School children
- Young people
- Public play areas without supervision, such as playgrounds, parks or similar
- Swimming pools without supervision, such as outdoor pools, adventure pools or similar
- Leisure parks

**Note**

When using wood chips as fall protection, it is important to use high-quality material with a low percentage of bark, especially for one-legged pieces of equipment. The prescribed inspections of the structural stability must be carried out with particular care with regard to the condition of the stand posts and any rot damage in the lower trunk area. Please also refer to the note on the limitation period for the assertion of claims for defects in our General Terms and Conditions.



Photo © Paul Upward



The photo shows different tensioning ropes, Photo © Paul Upward

**Components**

**Order No. 7.65000**

- 2 Poles with steel feet
- 4 Tensioning ropes
- 1 Rope suspension with 3 swing ropes, suspended on rotating universal joints

**Order No. 7.65500**

- 2 Poles with steel feet
- 4 Tensioning ropes
- 1 Rope suspension with 3 pendulum seats at with hose covered chains, suspended on rotating universal joints

**Swing Rope Equipment  
Swing Rope Equipment  
with pendulum seats**



Order No. 7.65000 Swing Rope Equipment



7.65000



7.65500



**Order No. 7.65000 / 7.65500**  
**Swing Rope Equipment**

Safety distance →  
 Device dimensions ●  
 Functional distance —

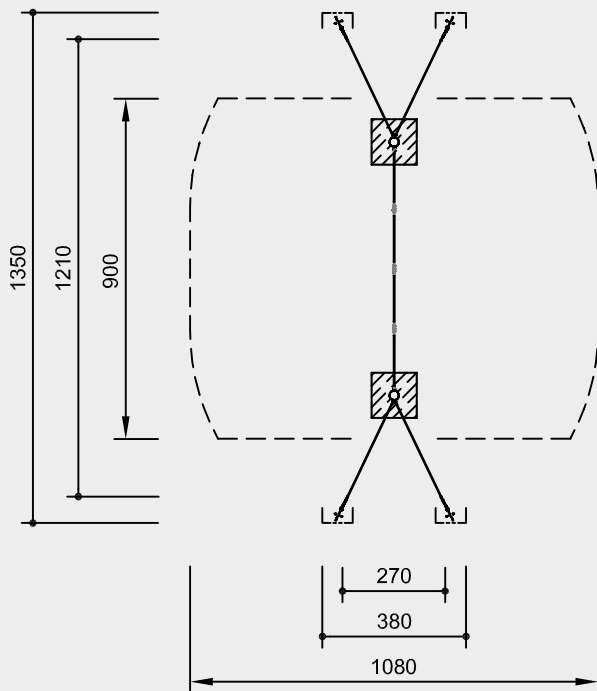
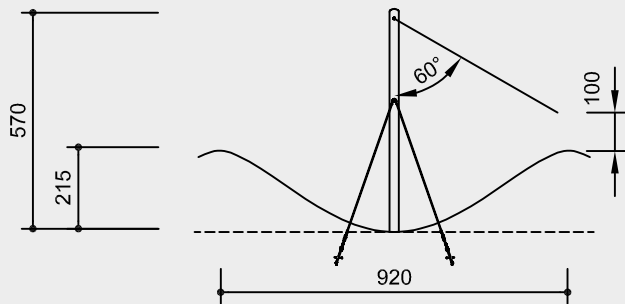

Scale 1:200

Safety check according to DIN EN 1176 and "safety in another way"

**Dimensions**

(small deviations possible)

**Order No. 7.65000**

**Swing Rope Equipment**

Height	5.70 m
Width, including tensioning ropes	12.10 m
Length of swing ropes	4.40 m
Weight	440 kg

**Order No. 7.65500**

**Swing Rope Equipment with pendulum seats**

Height	5.70 m
Width, including tensioning ropes	12.10 m
Length of swing ropes	4.30 m
Weight	450 kg

**Installation information**

Surfacing requirements corresponding to a fall height of ≤ 1.00 m when the ground is levelled in the recommended way or without hill ≤ 3.00 m

**Foundations**  
 2 items 120 x 120 x 60 cm  
 Excavation depth 80 cm  
 4 items 80 x 80 x 60 cm  
 Excavation depth 100 cm

**Attention:**

**Exact measurements may vary, for all installation dimensions refer to current installation instructions.**

Technical changes reserved.

**Technical information**

Equipment made of non-impregnated mountain larch

**Peeled white**

Palisades peeled white means that bark, cambium and sapwood are removed, the natural shape of the trunk is preserved and can be experienced



**Bevel cut**

Vertical stand posts with bevelled end grain section as constructive wood preservation measure



**Richter Hercules type rope**

Richter Hercules type rope, a combination of galvanised six-strand steel cables and polyester yarn, diameter > 20 mm, laid and glued with very good abrasion resistance, strong sheathing even in the case of damage by puncturing



**Aluminium rope pressing**

Aluminium rope pressing, cylindrically pressed, with rounded ends



**Universal joint**

Drop-forged, hot-dip galvanised universal joint, consists of two sintered bushes, for free swinging in any direction



**Rotating rope connection**

Rotatable fitting without dangerous openings, with sintered bush with integrated swivel to ensure the rope untwists



**Double rope connection**

Connection for complicated swing and swivel motion



**Sintered bush**

For all reciprocating movements we use sintered plain bearings which are self-lubricating in use and can easily be exchanged if necessary



**Ground anchor**

All parts used for anchoring to the ground are made of hot-dip galvanised steel or stainless steel



Standard colour rope: rainbow

**Order No. 7.65500**

**Swing Rope Equipment with pendulum seats**

**Pendulum seat**

Pendulum seat with a large rubber surface. Soft, protective edge and steel insert



**Chains**

Chains made of hot-dip galvanized steel (1.4301 / 1.4571 at extra charge) welded before galvanising, short-linked, without eyelets on the connecting parts, easy to exchange and shorten



**For more detailed explanation of the quality characteristics see price list.**



7.65000



7.65500