



Play value

The well designed Mushroom Springs gives off water when the hemisphere on top gets pressed down. The water comes out like a circular veil. When the hemisphere is pressed once, a valve is activated which stops the water flow after 25 seconds (from 0 up to 10 seconds adjustable), even if pressed permanently. Due to its agreeable design, the Mushroom Springs can also be used in less natural play surroundings.

Fundamental characteristics

- High-quality design
- Automatic water stop
- Unique and original
- Incentive for playing: hemisphere, water
- Movement: physical effort

Recommended for

- School children
- Supervised play areas, such as kindergartens, schools, after-school programmes or similar
- Public play areas without supervision, such as playgrounds, parks or similar
- Swimming pools without supervision, such as outdoor pools, adventure pools or similar
- Water play areas without supervision

Barrier-free

- Independent play



Photo © Paul Upward

Planning information

Individual solutions for the water supply must be devised, depending on the plans. Up-to-date details on the connection for the water supply and other technical information is available to download as a table at our website www.richter-spielgeraete.de.

**Mushroom Spring
Foundation Anchor
Mushroom Column Spring**



Order No. 5.18030 / 5.18032 Mushroom Column Spring



5.18000 - 5.18005



5.18006

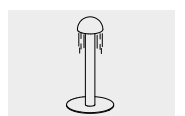

5.18030 / 5.18032

Order No. 5.18000 / 5.18002 / 5.18005
Mushroom Spring

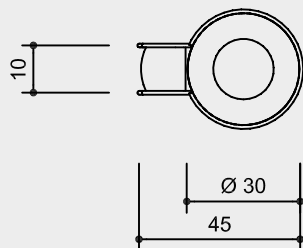
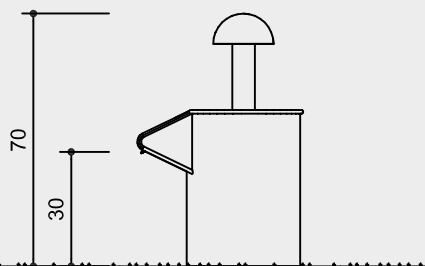

Order No. 5.18030 / 5.18032
Mushroom Column Spring

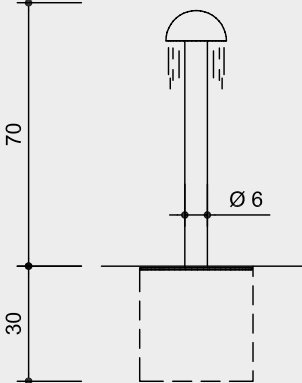

Order No. 5.18006
Foundation Anchor

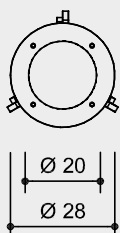
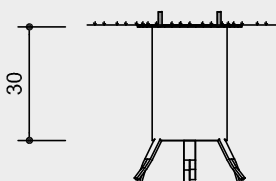

Safety distance —————>
 Device dimensions ———●———
 Functional distance ———|———

Scale 1:20

Safety check according to DIN EN 1176

Components

1 Part each

During the frost period the inset with the valve needs to be disassembled.

The opening can be closed with a winter lid **Order No. 0.97840** (see price list).

Attention:
Exact measurements may vary, for all installation dimensions refer to current installation instructions.
 Technical changes reserved.
For use in aggressive environments such as salt or chlorine water, the equipment is also available in marine grade steel (V4A).

Technical information

Equipment completely made of stainless steel, glass bead blasted, with self-righting pressure valve

Order No. 5.18006
Foundation Anchor
 made of galvanised steel

Dimensions
 (small deviations possible)

Order No. 5.18000 / 5.18002 / 5.18005
Mushroom Spring
 Height 0.70 m
 Diameter 0.30 m
 Width 0.45 m
 Weight 37 kg

Order No. 5.18004
 As above, but
 Height 0.80 m

Order No. 5.18006
Foundation Anchor
 Height 0.30 m
 Diameter 0.28 m
 Weight 8 kg

Order No. 5.18030 / 5.18032
Mushroom Column Spring
 Height 0.70 m
 Diameter 0.30 m
 Weight 24 kg

Installation information

Surfacing requirements recommendation: paving stone or similar with gully.

The Mushroom Spring **Order No. 5.18000** can be installed on natural stone, pedestal etc.

Order No. 5.18002 as before, but with programmable rinsing device for direct connection to pressure line.

The Mushroom Spring **Order No. 5.18005** can be installed on concrete Water Basins

Order No. 5.22000, 5.22100, 5.24200 and 5.24400.

Foundations
Order No. 5.18006
Foundation Anchor
 1 Stück 60 x 60 x 30 cm
 Aushubtiefe 50 cm

The Mushroom Column Spring **Order No. 5.18030** can be installed in site concrete foundation.
Order No. 5.18032 as before, but with programmable rinsing device for direct connection to pressure line.

Foundations
Order No. 5.18032
Mushroom Column Spring
 1 item 40 x 40 x 30 cm
 Excavation depth 60 cm

The Mushroom Spring and the Mushroom Column Spring needs to be connected directly to the mains water (2.5 - 5 bar); Connection thread on Equipment 3/4 inch inside (we recommend a compression proof diameter 3/4 inch), water requirement approx. 10 l/min at 3 bar



5.18000 - 5.18005



5.18006



5.18030 / 5.18032